

CORNING

Armorcast™ Structural Material 4560 Kits and Sheath Repair Kit 4561 Instructions

P/N YP-2763-0217-8

Issue 2

related literature | Search [corning.com/opcomm](https://www.corning.com/opcomm). Click on "Resources/Standard Recommended Procedures."

CONTENTS

1.0 General	2
2.0 Kit Contents	2
3.0 Product Preparation	2
4.0 Level Wrapping Technique	2
5.0 Uphill Wrapping Technique	3
6.0 Downhill Wrapping Technique	3
7.0 Armorcast™ Removal	4
8.0 Sheath Repair Applications	4
9.0 Lead Auxiliary Repair Applications	5

1.0 GENERAL

Armorcast™ Structural Material is a stretchy knit fiberglass fabric strip, saturated with a curable black polyurethane resin. When properly applied according to the following instructions, Armorcast will solidify into a tough, durable composite which is ideal for mechanical stiffening and protection of cables and splices.

2.0 KIT CONTENTS

2.1 Armorcast Structural Material Kit 4560 includes:

- Armorcast in Foil Pouches, 5 or 10 rolls as the package label indicates
- Protective Gloves, one pair per roll of Armorcast

2.2 Armorcast Sheath Repair Kit 4561 includes:

- Armorcast in Foil Pouch (1 roll), 3.8 in. x 15 ft. (97 mm x 4,57 m)
- VM Tape (1 roll)
- #50 Tape (1 roll)
- Vent Tube (1 each)
- Protective Gloves (1 pair)

2.3 Additional Materials Required:

- Water
- Sheath Scuff
- 4" (102 mm) wide VM Tape (included in 4561 Kit)
- 2" (51 mm) wide #50 Vinyl Tape (included in 4561 Kit)
- Muslin or Plastic Wrap
- B Sealing Tape
- Shield Bonding Materials

3.0 PRODUCT PREPARATION

3.1 Clean and scuff cable per standard procedure.

3.2 Make necessary repairs and close per instructions in sheath repair practice or lead auxiliary practice.

Note: If ambient temperatures are below freezing, warm cable and materials to above 35°F (+2°C) to insure best adhesion and cure speed.

3.3 Put on gloves and open top of foil pouch by tearing at notches.

Note: Carefully follow safety, health, and environmental information given on product label or the Safety Data Sheet (SDS).

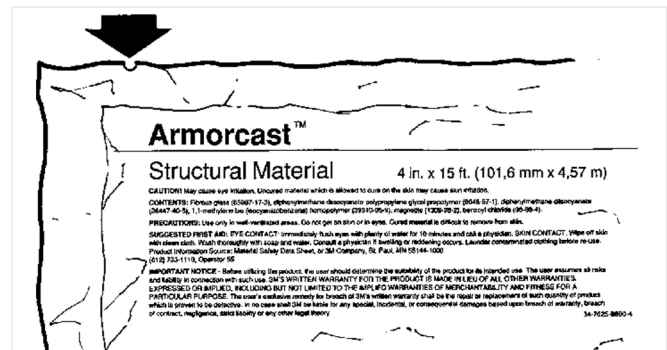

3.4 Tear apart pouch. Remove roll. Discard pouch.

Note: To prevent tearing of Armorcast material, hold material by the roll only. DO NOT APPLY FINGER PRESSURE TO THE UNROLLED PORTION OF ARMORCAST MATERIAL.

4.0 LEVEL WRAPPING TECHNIQUE

4.1 With the outside of the roll in a down position, start wrapping procedure at place designated in instructions for specific application.

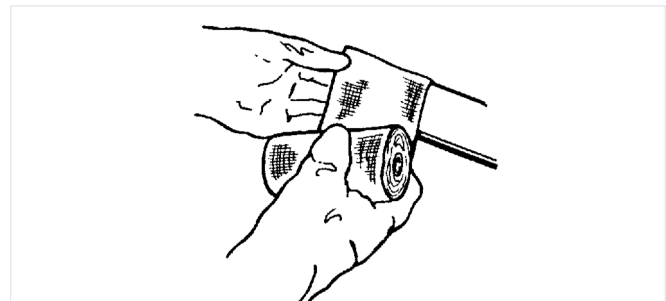

4.2 With slight tension on roll, wrap the entire length of area on the cable with 60% minimum overlaps.

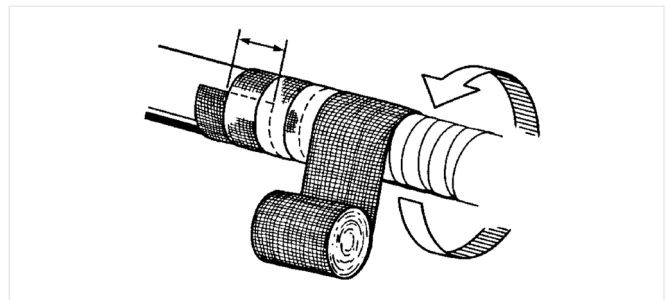

The following wrapping techniques will provide a neat and easy way to cover cable repairs and splices. They will also provide maximum strength by using the 60% overlap method. Changes in wrap diameter may be achieved by using one of the following methods:

5.0 UPHILL WRAPPING TECHNIQUE

5.1 Keep roll-to-work distance within 1" (25 mm).

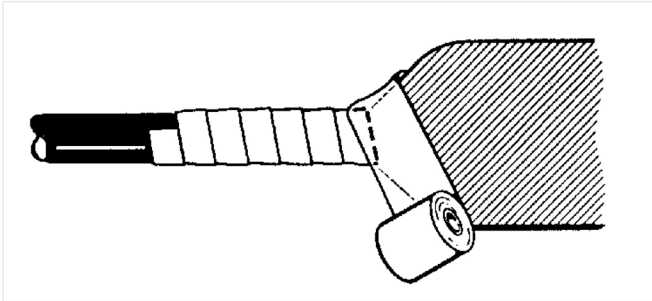

5.2 Fold material over and pull across cable. Continue to wrap using the 60% overlap which in turn will hold down the fold.

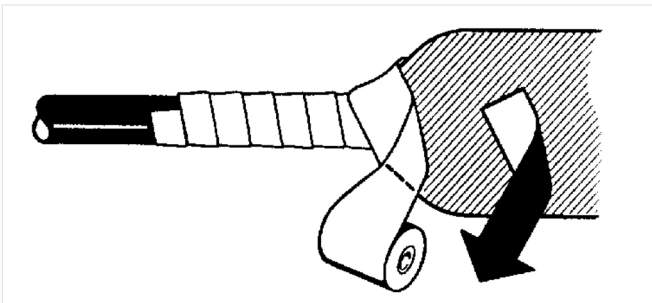

5.3 Additional folds can be made as needed to uniformly cover repair area.

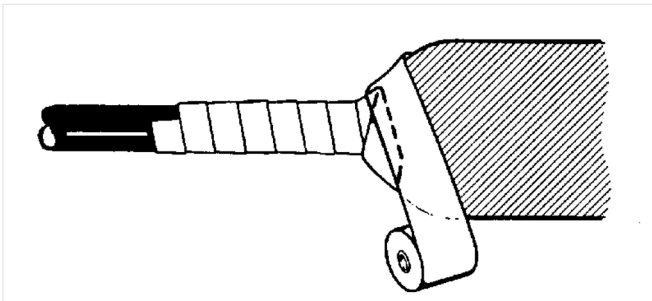

6.0 DOWNHILL WRAPPING TECHNIQUE

6.1 Extend the roll-to-work distance to 6" – 8" (152 mm – 203 mm).

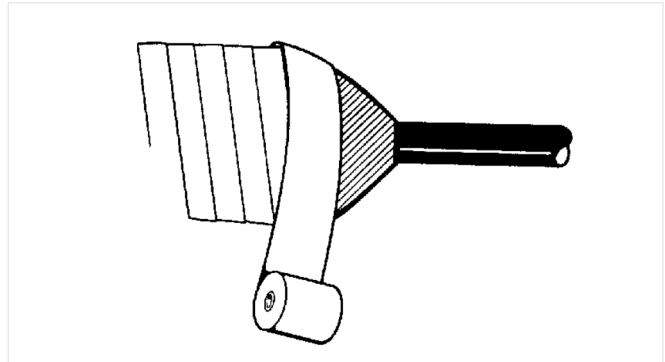

6.2 Slightly relax tension on the roll before folding. Turn over the roll and push back slightly towards work area. This allows the material to relax. Continue using this method until a 60% overlap is reached on the straight cable.

If the downhill wrap is on a slight taper, twist the roll slightly to take out some slack and continue to wrap on the axis as before with 60% overlap.

Note: To cure (harden the material), spray or pour water over the Armorcast™.

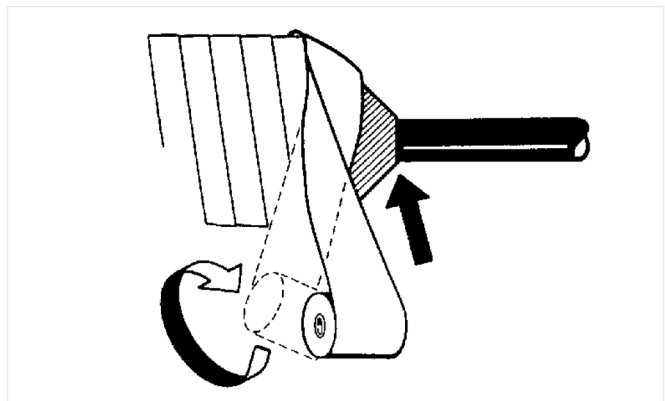

DO NOT TWIST INTO BOW TIE

7.0 ARMORCAST™ REMOVAL

7.1 Cut through Armorcast™ lengthwise with either a cable or chipping knife. **DO NOT** cut through underlying tape wraps.

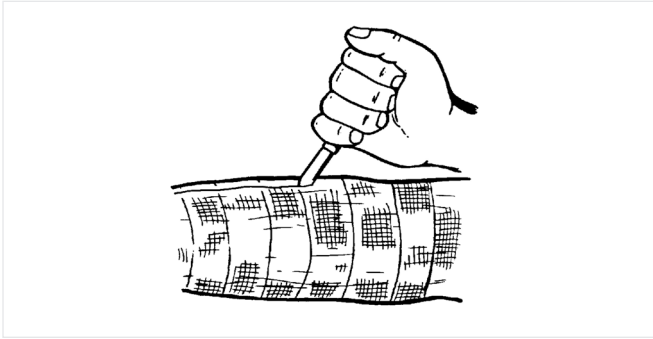

7.2 Use a large screwdriver or similar tool to pry the Armorcast part. Remove as large a piece as possible. Make additional cuts to remove parts which may be mechanically held.

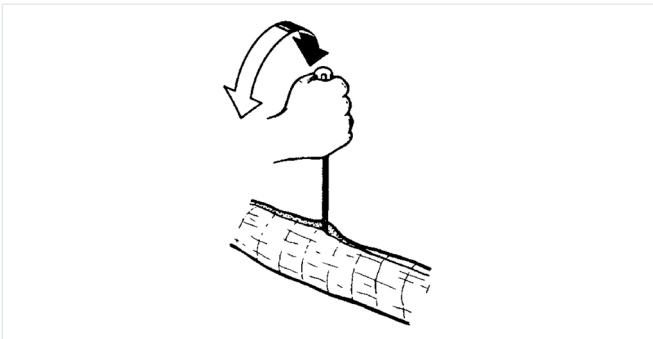

8.0 SHEATH REPAIR APPLICATIONS

Armorcast can be used to repair sheath damage and trouble openings on both pressurized and non-pressurized cable. **Installation can take place while cable is pressurized.**

Use steps identified with * only when working on cable under pressure.

8.1 Cut away damaged sheath and make repairs per standard procedure.

8.2 Clean grease and dirt from cable adjacent to repair section.

8.3 Scuff cable 12" (305 mm) on each side of repair section.

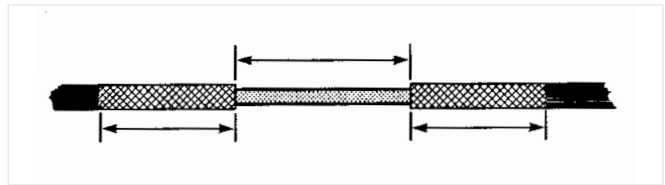

8.4 Install shield bond connectors per standard practice.

8.5 Wrap PIC conductors with polytape or pulp conductors with muslin per standard practice. Secure ends with a short length of #50 vinyl tape.

8.6 * Secure breather tube to the muslin wrap with a 2" (51 mm) square piece of VM Tape. Prepare the VM tape piece with a small split in the middle so that the tube fits snugly through it. Insert the tube into the slit and rub down to bond it to the muslin surface. For polywrap repairs, place tube between edges of the polywrap.

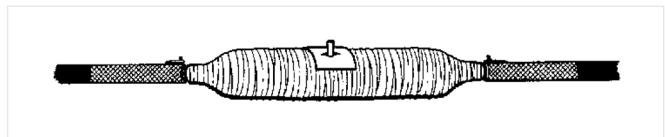

8.7 Attach ground braid to the shield connectors using two nuts on each connector. Tighten the lower nut to get a good mechanical and electrical connection. If an unused nut is available, back the upper nut off until it is flush with the end of the stud. This will help prevent the stud from puncturing later wraps.

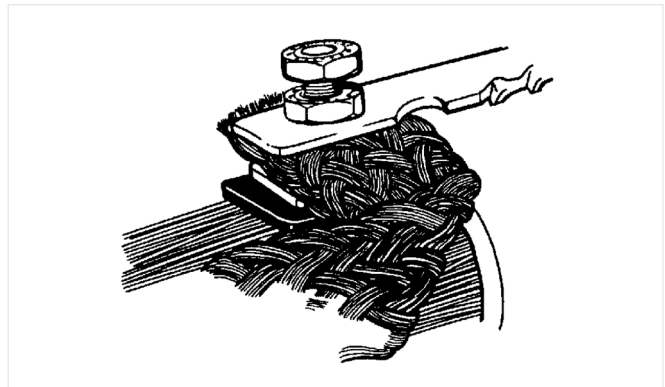

8.8 Wrap two layers of 2" (51 mm) #50 tape over shield connectors and studs.

8.9 Starting 4" (102 mm) beyond the #50 tape, apply half-lapped VM tape using moderate tension while wrapping and continue 4" (102 mm) beyond #50 tape at far end. Try to eliminate all but the smallest wrinkles by applying moderate tension.

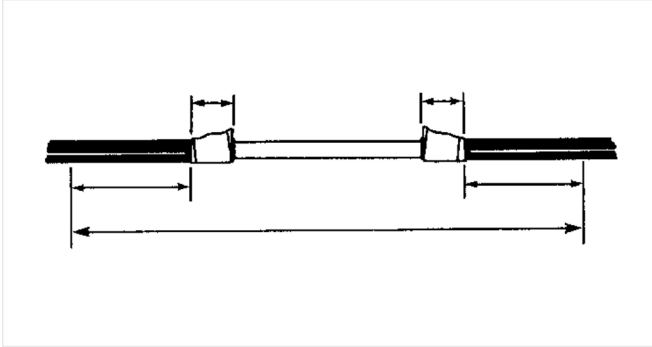

8.10 * When going over breather tube, do not cut the tape. Split the center of the VM wrap and pull it over the breather tube. Complete the VM wrap.

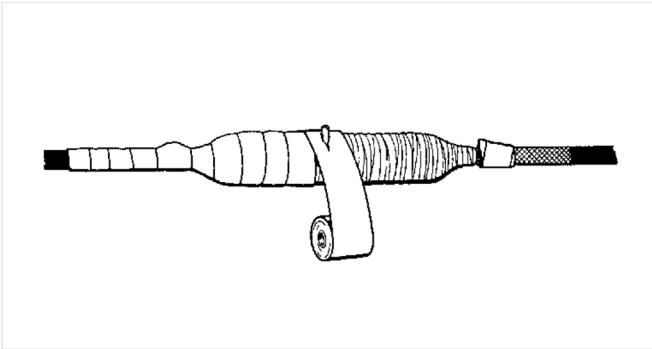

8.11 Overwrap the VM layer with two half-lap layers of #50 tape (highly stretched). Start and end at the center of the repair. The first layer should start going in the same direction as the previous VM layer. Position the #50 tape abutting tightly against both sides of the breather tube as the center is passed. Extend the #50 tape 2" (51 mm) past the ends of the VM tape.

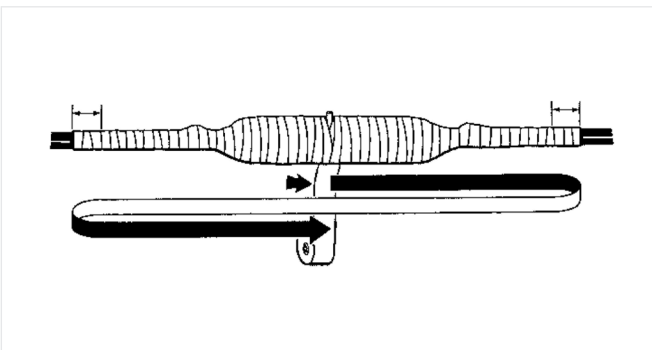

8.12 * When the wrap reaches the breather tube do not cut the tape. Allow the roll to hang. Prepare a 1/2" (13 mm) diameter plug of B sealing tape and a 2" (51 mm) square patch of VM tape. Pull out the breather tube and discard. Press plug into hole. Some plug should remain on the surface. Quickly place and immediately secure VM patch over plugged hole using four layers of highly stretched #50 tape. The #50 tape must completely cover the patch and overlap the edges.

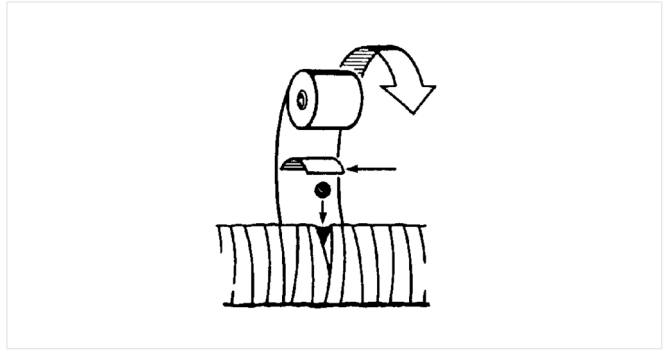

8.13 Following standard wrapping procedures, wrap the entire repair section with Armorcast™. Extend the Armorcast 2" (51 mm) past the #50 tape.

9.0 LEAD AUXILIARY REPAIR APPLICATION

Armorcast™ can be used to repair defective lead/polyethylene interface leaks. **Installation can take place while cable is pressurized.**

*Note: Use steps identified with * only when working on cable under pressure.*

9.1 Make sure surfaces are wiped free of dirt and grease, then scuff lead sleeve and a minimum of 12" (305 mm) of cable sheath on each side.

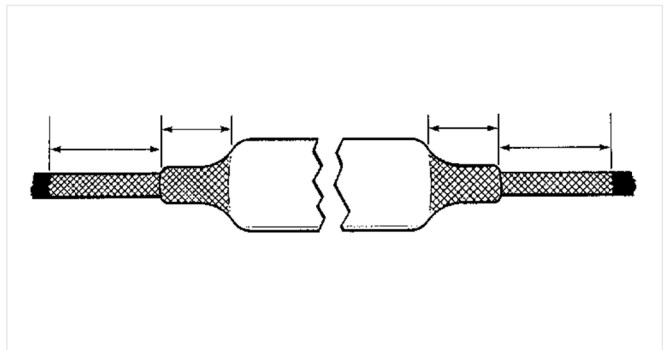

9.2 If the diameter of the lead auxiliary is 1" (25 mm) or more greater than the cable diameter, or if the angle of the transition is steeper than 45°, build up a B sealing tape cone to make a taper of 45° or less between the lead sleeve and the cable.

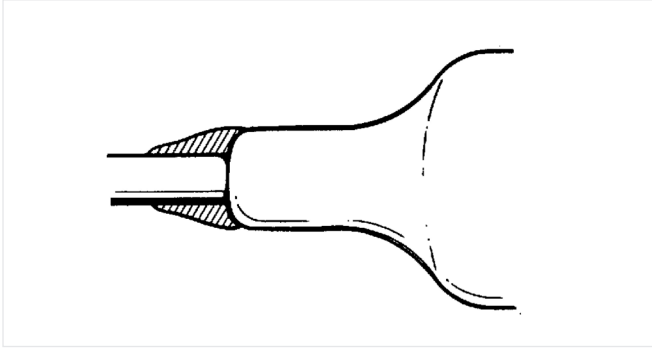

9.3 * Secure the kit breather tube at the lead to cable junction with a 2" (51 mm) square of VM tape. Prepare the tape making a small slit to allow the tube to fit snugly. Fit the tube into the slot and rub the tape down onto it. If step 9.2 was followed to build a 45° cone, be sure the vent tube provides a clear leak path.

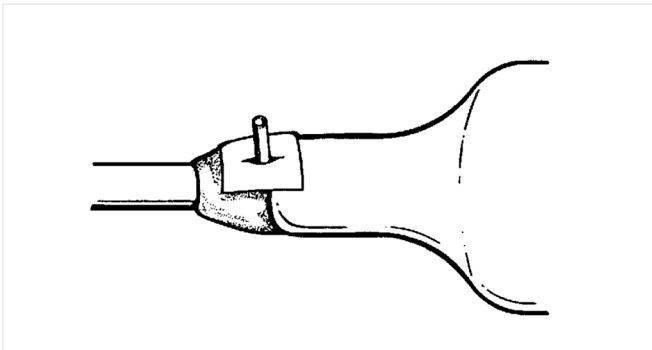

9.4 Starting 4" (102 mm) down the cable sheath, half lap VM tape to at least 4" (102 mm) onto the lead sleeve.

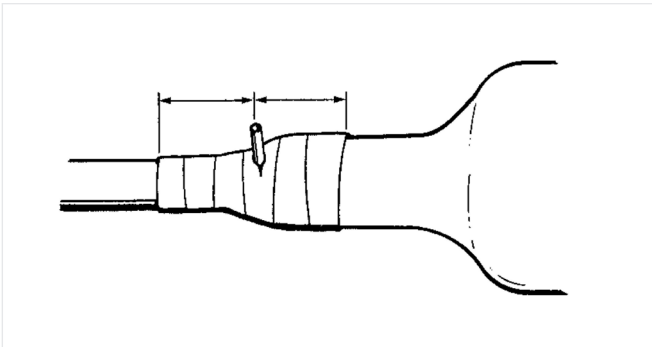

9.5 If the lead auxiliary neck is less than 7.5" (191 mm) long it may be necessary to carry all of the following tape wrap layers up onto the maximum diameter. If so, do not end any wrap on the slope, but continue at least 2" (51 mm) along the large diameter.

9.6 * When going over the breather tube, do not cut the tape off. Slit the center of the VM and pull over breather tube. Complete VM wrap.

9.7 Overwrap the VM tape layer with two half lap layers of #50 tape, highly stretched. Start and end at the center of the repair. Wrap uphill 2" (51 mm) beyond the VM tape, back downhill 2" (51 mm) beyond the VM tape, then back uphill to the center to complete the #50 tape wrap.

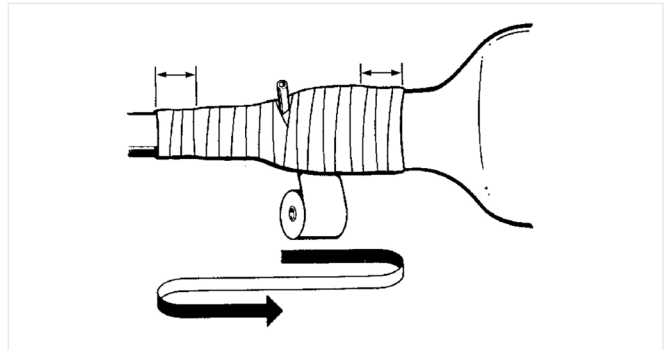

9.8 * When passing by the vent tube, wrap the #50 tape snugly abutting either side of the vent.

9.9 * Do not cut the #50 tape. Allow the roll to hang. Prepare a 1/2" (13 mm) plug of B sealing tape. Prepare a 2" (51 mm) square patch of VM tape. Pull out the breathing tube and discard. Press the plug into the hole, secure the VM patch over the plug and immediately overwrap with at least four layers of highly stretched #50 tape over the VM patch. The #50 tape must cover it completely and overwrap the edges.

9.10 Follow standard wrapping procedures and wrap the entire section with Armorcast™.

NOTES:

Corning Optical Communications LLC • 4200 Corning Place • Charlotte, NC 28216 USA
800-743-2675 • FAX: 828-325-5060 • International: +1-828-901-5000 • www.corning.com/opcomm

Corning Optical Communications reserves the right to improve, enhance, and modify the features and specifications of Corning Optical Communications products without prior notification. A complete listing of the trademarks of Corning Optical Communications is available at www.corning.com/opcomm/trademarks. All other trademarks are the properties of their respective owners. Corning Optical Communications is ISO 9001 certified. © 2019 Corning Optical Communications. All rights reserved.